

SAFETY COMPACT S type universal switch cabinet

Installation, maintenance and operating instructions

Contents

General notes

Description of the SAFETY COMPACT S series

Frame construction

Transportation and storage

Installing and screw-mounting the control panels

Location

Screwing together the transport units

Treatment of the locations where contact to the busbars is made

Screw connections to the busbar

Screw-mounting the control panels

Attaching the control panels to the floor

Attaching the labyrinth roofs

Installation of side walls

Final work before commissioning

Maintenance instructions

Torques for electrical screw connections

Operating instructions

General notes

These operating instructions apply to finished, type-verified and partially type-verified SAFETY COMPACT combinations with integrated appliances. The design and construction of control panels conform to DIN EN 60439 part 1/IEC 439-1.

The switch cabinets are intended for installation in rooms under normal operating conditions. The ambient temperature must not exceed +40°C and its mean value over 24 hours must not exceed +35°C. The lower limit for the ambient temperature is -5°C. In the case of operating conditions not falling within these limits please contact us.

The operative reliability and service life of the switch system is influenced by its correct operation and on regular maintenance work being carried out on it. Ignoring the information given in these instructions can put the warranty rights at risk.

In the case of inquiries please tell us all the data given on the performance plate of the switch system and the switching devices in order to allow rapid processing.

Description of the SAFETY COMPACT S series

Protective systems

The following protective systems are available:

IP 00/20/31/40/41/42/50/51/54 conforming to DIN VDE 0470 part 1, EN 60 529, IEC 529

General structure of the switch system

The Safety Compact S switch cabinet consists of a frame construction with elements such as string pieces, corners and reinforcement plates which are assembled by means of simple mechanical assembly.

The sheet cover plates on the sides, the back and on top are made from folded steel sheets which are screwed to the sections making up the string pieces in such a way that their outer surfaces are flush with the string pieces.

All the doors are of the attached type and are also made from folded steel sheet. The doors can either open to the right or to the left (please state type in the order). All the doors are closed by means of espangolettes. The angle the doors open to is 110°. A special version opening to 180° is also available.

When extending the switch system, the complete cover of one end is unscrewed and used to cover the end of the newly attached additional panel.

Internal dividing wall

For separating the control panels, (depending on order) steel sheet walls are available with openings for copper and cable connections.

Power rails

The power rails are made from copper. The cross-section of the power rails is chosen to match the nominal current I_n .

Frame construction

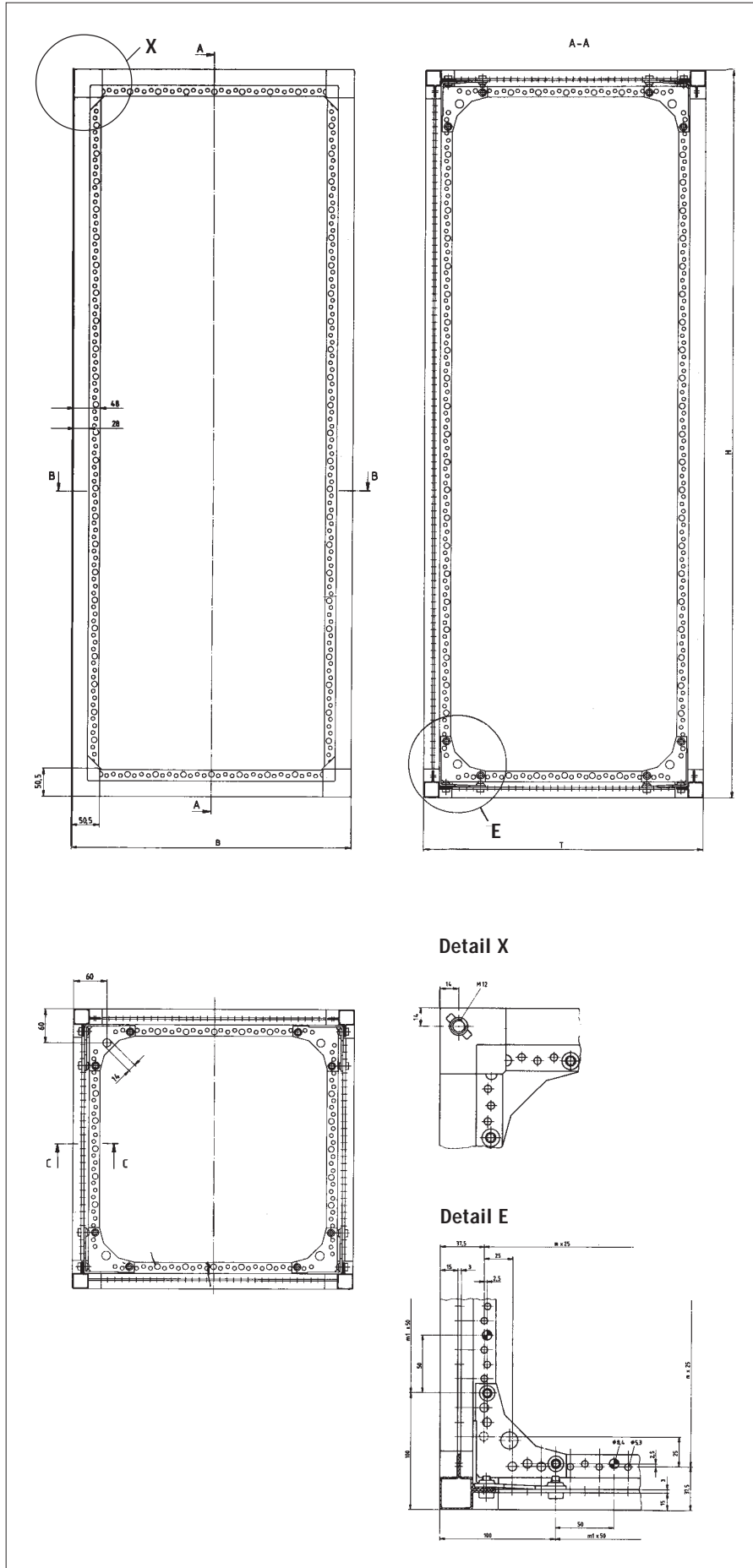

Transportation and storage

Generally the control panels are supplied as single transportation units with ring bolts.

If required, the control panels are welded into plastic film and shipped in transportation boxes. The accessories listed on the enclosed list are packaged in a further transportation box.

When the shipment is delivered it must be checked against the delivery note to ensure that it is complete and not damaged. If the shipment is incomplete an inventory has to be drawn up immediately together with the carrier.

If goods arrive damaged, in addition an expert should be enlisted and a report should be drawn up and photographs be made showing the extent of the damage and the cause of the damage. The control panels or transportation units must be correctly located at the site where they are to be installed, onto a clean, dry and even surface. The orientation must be maintained (do not lay on side, do not stand upside down!) When unloading and unpacking the control panels during difficult weather conditions, water must be prevented from entering into the control panels.

When lifting gear is available, crane attachments with suitable rope lashings have to be used. The hooks on the ropes are inserted in the ring bolts provided. When lifting, it must be made sure that the base of the control panel remains roughly horizontal. If the control panels cannot be installed immediately, they must be stored under normal operating conditions in enclosed and dry rooms free of dust.

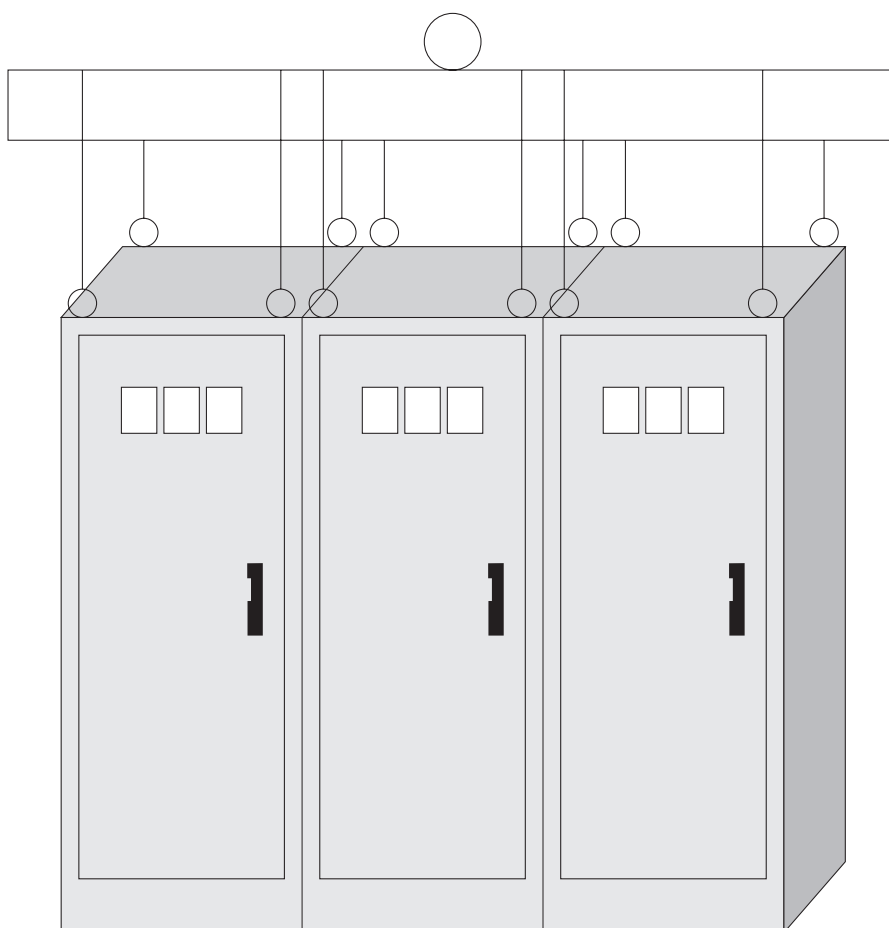

Warning!

During transportation note that the panels may be top-heavy and protect against tipping over.

Installation and screw-mounting the control panels

The erection and installation of the control panels must be carried out or supervised by an electrician. The control panels can be put up on foundation rails made from sectional steel or on a frame made from sectional steel (elevated foundation) or directly onto the concrete floor. The position of the holes in the ceiling for the busbars or the connection cables must be checked first.

Location

The following factors must be considered while locating the control panels:

- the panels must not be located near to heat sources
- control panels with ventilation slits on the back must be placed at a distance of 250 mm from the wall
- dust and moisture must be prevented from entering the control panels
- in order to facilitate handling, a distance of 250 mm should be maintained between the wall and the side of the unit

Warning!

When pushing and screwing the panels and busbars together, the supports for the busbars must not be damaged or mechanically stressed.

The installation material for assembling the transportation units, such as screws and connection brackets for the busbars, are included with the delivery.

In order to achieve trouble-free functioning of the switching device combination, the transportation units should be placed on a horizontal foundation.

In order to facilitate this, it is recommended that the transportation units be located on a foundation frame. These foundation frames can be aligned on the concrete of the unfinished floor before the flooring plaster is cast. Foundation frames are not part of the control cabinet delivery.

Screwing together the transportation units

After the transportation units have been placed in a row and aligned they are now screwed together as follows:

- the string pieces at the front and at the back of two neighbouring control panels must be screwed together, from 800-1000 mm depth also at the upper and the lower ends, by means of the frame connection elements included
- the transportation brackets for the busbar system which have already been aligned and attached to one side must be screwed together; due to the tolerances it may be necessary for the screw connection for the busbar bracket to be loosened
- after the control panels have been aligned, the transportation bracket of the M 12 thread screw attachment for the busbars has to be tightened to a torque of 70 + 10% Nm
- the brackets for the PEN/PE/N rail located near the floor will be delivered loose and have to be screwed on at both sides

Treatment of the locations where contact to the busbars is made

The contact areas for screw attachment of/to the busbars have to be thinly greased using the lubricant "BECHEM BERULUB FK60 Part-no. 9012899501".

A later treatment or repair may only be carried out using the lubricant mentioned above.

Screw connections to the busbar

For screw connections to the power rails, screws of property class 8.8 and nuts of property class 8 must be used. Screws and nuts must not be lubricated.

Attaching the control panels to the floor

The control panels can either be attached by screws or by welding them on. For this purpose there are 14 mm holes in the reinforcement plates. Use M 10 hexagonal head screws of property class 8.8 for fastening. The screw-on installation brackets for welding to are available but not included in the scope of delivery (accessory).

After welding, the seams must be treated with corrosion protection paste.

Warning!

Welding directly to the frame structure is not permitted.

Attaching the labyrinth roofs

For switch systems with labyrinth roofs, they have to be set to the greatest possible separation after installation.

Then the ring bolts may be removed. The hexagonal screws holding the rings have to be screwed back in afterwards in order to close up the holes in the sections making up the frame.

Installation of side walls

The side walls are installed using the enclosed plastic spacer sleeves and one aluminium spacer sleeve per side wall (for reliable earthing).

Final work before commissioning

Connect the control panels and commission in accordance with the valid DIN VDE 0100 part 610 regulations (Construction of power installations with nominal voltages up to 1000 V – Testing: initial tests).

After completion of the setting-up and connecting, the whole switch system must be checked for correct installation, and the integrated devices and facilities have to be checked for correct functioning.

This work is structured as follows:

- if they have been buckled during transportation, repair the sheet metal walls and doors before commissioning, so that the distance to the charge-carrying elements is correct
- clean the installation, particularly the isolating elements, such as the brackets holding the busbars and the grommets
- repair any damaged varnish
- check that the phase orientation of the electricity supply is correct
- check that the screw connections to the transportation brackets are tight (here the same torque should be used as during installation)
- check the settings of the protective equipment
- test switch the switching devices integrated into the control panel as described in the applicable operating instructions
- attach protective covers

Maintenance instructions

The reliability and service life of the switch system with the integrated switching devices depends, among other things, on correct and careful maintenance. The maintenance periods and the maintenance to be carried out can be found in the operating instructions for the switching devices.

Depending on the situation on site, the isolating parts have to be cleaned, particularly when a lot of dust settles on them. In order to determine the correct servicing periods depending on the local situation, it is recommended to have the installation serviced after the first year of operation.

The maintenance may only be carried out by, or supervised by, an electrician observing the safety regulations and VDE regulations.

Maintenance covers the following work:

- cleaning the switch system of dust deposits
- checking all the screw connections on the busbars and connections to power rails or cables as specified in the following table

Torques for electrical screw connections				
Screw size	Connection of devices in general		Cu power rail connections and connections for the power switch type ME 07	
	Nominal torque	Minimum torque for tests	Nominal torque	Minimum torque for tests
< M 3	0.5 - 0.56	0.43		
M 3	0.8 - 0.90	0.70		
M 3.5	1.0 - 1.1	0.80		
M 4	1.4 - 1.5	1.10		
M 5	2.7 - 3.0	2.30		
M 6	5.4 - 6.0	4.20	8	6
M 8	14.0 - 16.0	12.00	20	15
M10	23.0 - 26.0	20.00	41	30
M12	36.0 - 40.0	30.00	70	50
M16	54.0 - 60.0	45.00	140	100

Warning!

Note the torques given in the operating instructions applying to the integrated devices.

- Check the devices integrated into the control panel as described in the applicable operating instructions
- Check all the connection points to the earth cable
- Check the protective earth connections

Operating instructions

The operating instructions to be used are the valid operating instructions for the integrated switching devices and, if available, the operating instructions for the switching device combination. All warnings must be heeded.

Warning!

When an NH safety load-break switch is installed, the installation must be switched on rapidly.

It must be ensured, when operating the low voltage switching device combinations, that the panel doors are closed, as during operation the power switches can generate dangerous electric arcs.

Warning

S a f e t y
for people,
the environment,

plant and
machinery.

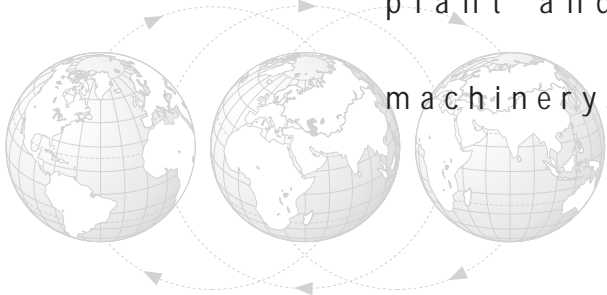

It is inevitable that parts of electrical devices will be at a dangerously high voltage during operation.

Installation, commissioning, maintenance, modifications and additions to these installations and the devices included in them may therefore only be carried out by qualified technicians observing the generally accepted safety regulations.

Doors and covers must be properly closed and locked during operation.

Ignoring this warning can lead to death, serious injury or damage.

Operating instructions
BARTEC Sicherheits-Schaltanlagen GmbH
Printed in Germany
Edition 02/2001

Reservation

Technical data subject to change without notice. No claims for damages arising from alterations, errors or misprints shall be allowed. Attention is drawn to the applicable standards and regulations on safety components and systems together with the relevant operating and installation instructions.